

# ALCOR – II R

CNC Profile Machining and Cutting Center (8 Servo Axis and 14 Machining Axis for PVC)

Automation by  
**FANUC**



The 8-servo axis CNC profile machining and cutting center ALCOR – II R has been developed to carry out all – in one cutting, milling drain channel opening, punching, and marking operations on PVC profiles. Thanks to its 14 standard machining and individual operating units, ALCOR – II R has been designed to offer maximum efficiency in less time.

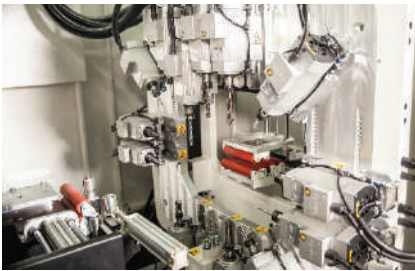

Equipped with a high performance powertrain featuring 13 standard individually cooled spindle motors, a dedicated slot opening motor, and a separate saw blade motor, the ALCOR II R delivers unparalleled multitasking capabilities, enabling simultaneous execution of 15 operations and unrestricted processing across all four profile surfaces.



Equipped with a 10-profile feed conveyor, ALCOR - II R leverages batch processing technology for enhanced operational efficiency

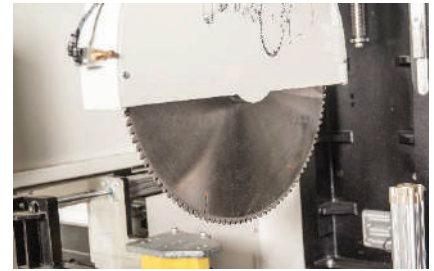

Unlock a vast array of cutting possibilities with the unit's 550mm diameter saw blade, capable of tackling any angle between 30° and 150°. This expansive cutting range empowers users to maximize their creative and production potential.

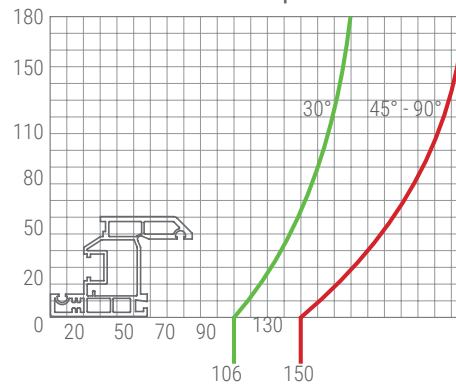
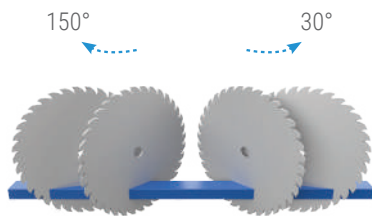

# ALCOR – II R

CNC Profile Machining and Cutting Center (8 Servo Axis and 14 Machining Axis for PVC)

## CONFIGURABLE SPINDLES

- 13 Standard air cooled high speed spindle motors.
- Standard Triple Slot Drilling motor.
- Optional 14<sup>th</sup> spindle.
- All motors configurable before shipping at the factory.

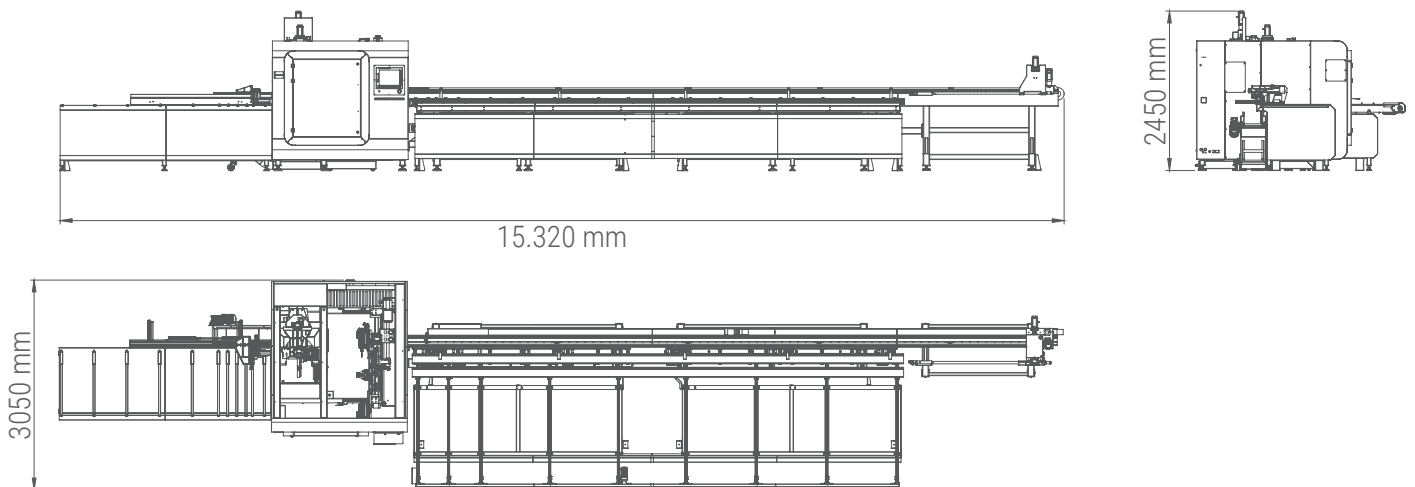
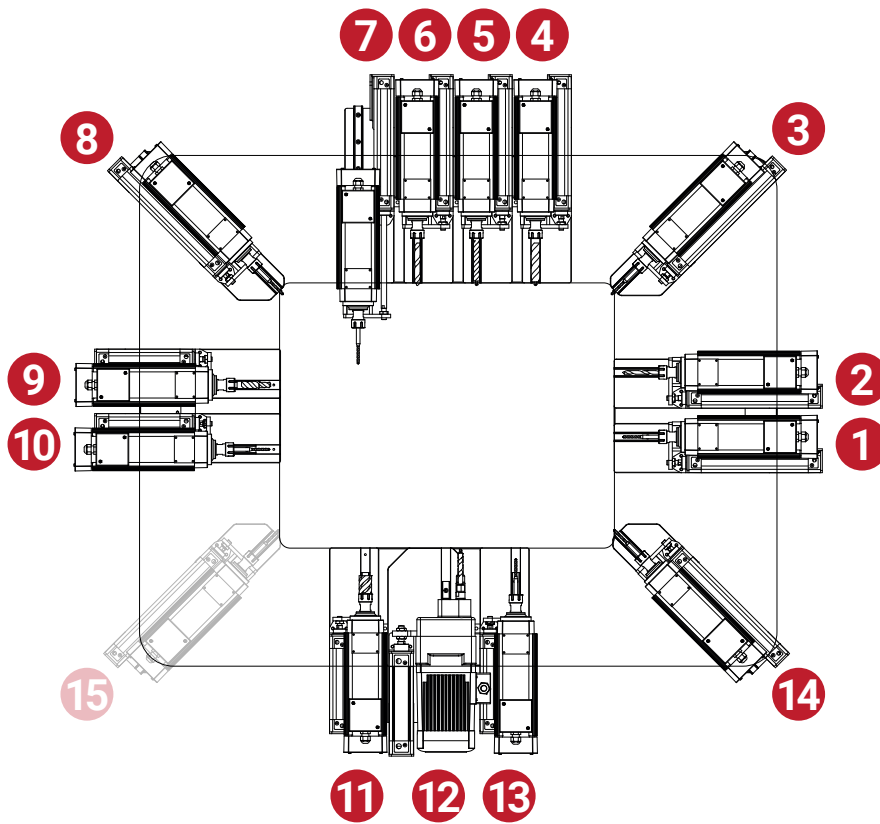

# ALCOR – II R

CNC Profile Machining and Cutting Center (8 Servo Axis and 14 Machining Axis for PVC)

## POSITIONING SPEED

X1 Axis (Longitudinal)	40 m/min
Y1 Axis (Lateral)	60 m/min
Z1 Axis (Vertical)	60 m/min
Z2 Axis (Cutting unit vertical movement)	42 m/min
C2 Axis (Cutting unit rotation)	166°/sec
XL Axis (Drive robot)	90 m/min

## AIR

Pressure	6-8 Bar
----------	---------

## ELECTRICAL

Max. Power	50.45 kW
Voltage	400V 3N PE AC
Frequency	50-60 Hz

## CUTTING UNIT

Cutting angles span	30° / 150°
Saw blade diameter	550 mm
Saw blade motor power	3kW - 4HP

## MILLING UNIT

Fan cooling spindles	13
Max. Power	1.1 kW
Maximum speed	18.000 rpm
Tool holder	ER 20
Special design motor for 3ple grip slot drilling	1
Max. Power / speed	0.75 kW / 3000 rpm
Drill diameters	10 mm / 12 mm / 10 mm
Maximum number of machining units	14

## LOADING AND UNLOADING UNIT

Minimum profile loading length	1200 mm
Maximum profile loading length	7500 mm
Minimum profile unloading length (90° - 90°)	270 mm
Profile loading capacity	10
Automatic chip discharge conveyor unit	●
Belt-driven profile discharge unit	○

## GRIPPER AXIS TRAVEL

YL Axis (Lateral) min. / max.	20 mm / 117 mm
ZL Axis (Vertical) min. / max.	20 mm / 115 mm

## CONTROL UNIT

Industrial PC - Touch Screen	15"
Data transfer over remote network connection, Ethernet and USB	●
Barcode writer	●
Compatibility with optimization programs	●

## OPERATIONAL AREA

Automatic lubrication in processing area	●
Cabinet providing protection in processing zone	●
FESTO pneumatic system	○
Air Tank	○

● Standard ○ Optional