

ALCOR - I

CNC Profile Cutting Center (5 Servo Axis)



The 5 servo axis CNC profile cutting center **ALCOR - I** is designed to cut profiles made of aluminum, PVC and all kinds of light alloy profiles.

The cutting unit with a 550 mm diameter saw blade for cutting at every angle between 30° and 150° offers a wide cutting range to users.

Thanks to the feeding capacity of 10 profiles, the conveyor structure enables batch processing, letting the machine to be used in the most efficient manner.

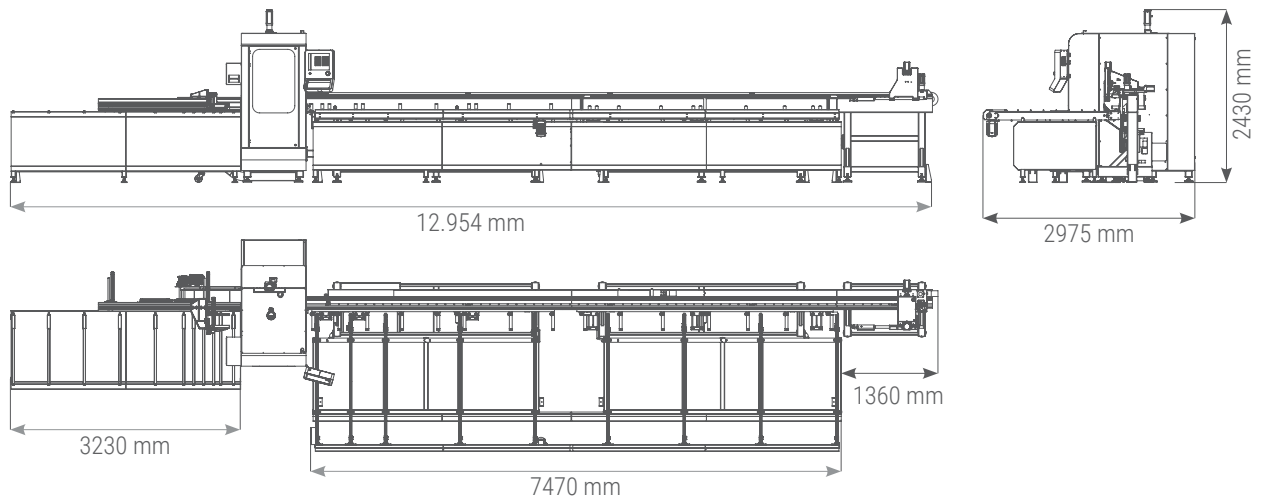
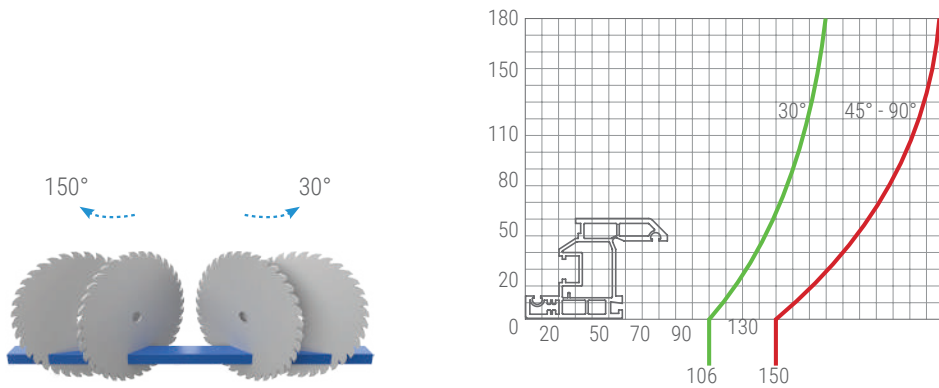

ALCOR - I

CNC Profile Cutting Center (3 Axis)

AXIS TRAVEL

Z2 Axis (Cutting unit vertical movement)	260 mm
C2 Axis (Cutting unit rotation)	120°
XL Axis (Drive robot)	min. 700 mm / max. 7500 mm

POSITIONING SPEED

Z2 Axis (Cutting unit vertical movement)	42 m/min
C2 Axis (Cutting unit rotation)	166°/sec
XL Axis (Drive robot)	90 m/min

ELECTRICAL

Max. Power	6.75 kW
Voltage	400V 3N PE AC
Frequency	50-60 Hz

CUTTING UNIT

Cutting angles span	30° / 150°
Saw blade diameter	550 mm
Saw blade motor power	3kW - 4HP

LOADING AND UNLOADING UNIT

Minimum profile loading length	700 mm
Maximum profile loading length	7500 mm
Minimum profile unloading length (90° - 90°)	270 mm
Profile loading capacity	10
Automatic chip discharge conveyor unit	•

GRIPPER AXIS TRAVEL

YL Axis (Lateral) min. / max.	20 mm / 150 mm
ZL Axis (Vertical) min. / max.	20 mm / 140 mm

CONTROL UNIT

Industrial PC - Touch Screen	15"
LS automation package	•
Oz Machine Softcut	•
Data transfer over remote network connection, Ethernet and USB	•
Barcode writer	•
Compatibility with optimization programs	•
FANUC automation package	○

OPERATIONAL AREA

Automatic lubrication in processing area	•
Guard cabin for cutting area	•
FESTO pneumatic system	○
Air Tank	○

• Standard ○ Optional